



Differential Pressure Gauges for Low Pressure Applications With Alarm Contacts or Transmitter Capsule Element Series • Type 736.51

Pressure Gauges

Application

Stainless steel pressure gauge. Differential pressure measurement of clean, low pressure gases in corrosive environment

Sizes

4" and 6" (100 and 160 mm)

Accuracy

±1.5% of span

Ranges

1 to 65 "H₂O (2.5 to 160 mbar)
or equivalent other units of pressure or vacuum

Working Range

Steady: full scale value
Fluctuating: 0.9 x full scale value

Overpressure Safety

High pressure side overpressure safe up to 80 "H₂O (200 mbar) regardless of range

Static Pressure Rating

80 "H₂O (200 mbar) regardless of range

Operating Temperature

Ambient: -4°F (-20°C) to 140°F (60°C)
Medium: max. + 140°F (+60°C)

Temperature Error

Additional error when temperature changes from reference temperature of 68°F (20°C) ± 0.4% for every 18°F (10°C) rising or falling. Percentage of span.

Weather Protection

Weather tight (NEMA 4X / IP 65)

Standard Features

Connection

Material: 316 stainless steel
2 x 1/2" NPT

Capsule Element (exposed to pressure medium)
316 stainless steel

Pressure Chamber (exposed to pressure medium)
316 stainless steel

Movement (exposed to pressure medium)
Stainless steel

Dial (exposed to pressure medium)
White aluminum with black lettering

Pointer (exposed to pressure medium)
Black aluminum

Case (exposed to pressure medium)
Stainless steel case with stainless steel bayonet ring. Blow-out plug in back of case

Window (exposed to pressure medium)
Laminated safety glass



Gaskets (exposed to pressure medium)
Buna rubber (NBR) and silicone rubber

Gauge Mounting

Pressure inputs identified ⊕ and ⊖
⊕ high pressure
⊖ low pressure
Front flange or rear flange available
Optional pipe mounting pressure gauge support

Order Options

Other threaded pressure connection
Low pressure side 80 "H₂O (200 mbar) overpressure safe
Higher static pressure rating (not available with all ranges)
Accuracy ±1.0% (not available with all ranges)
Pipe mounting pressure gauge support (see data sheet AAM 09.07)
Front or rear flange
Pressure equalizing valve (see data sheet AAM 09.11)
Alarm contacts (see data sheet AAE 08.01)
Transmitters (see data sheet AAE 08.02)

Dimensions:

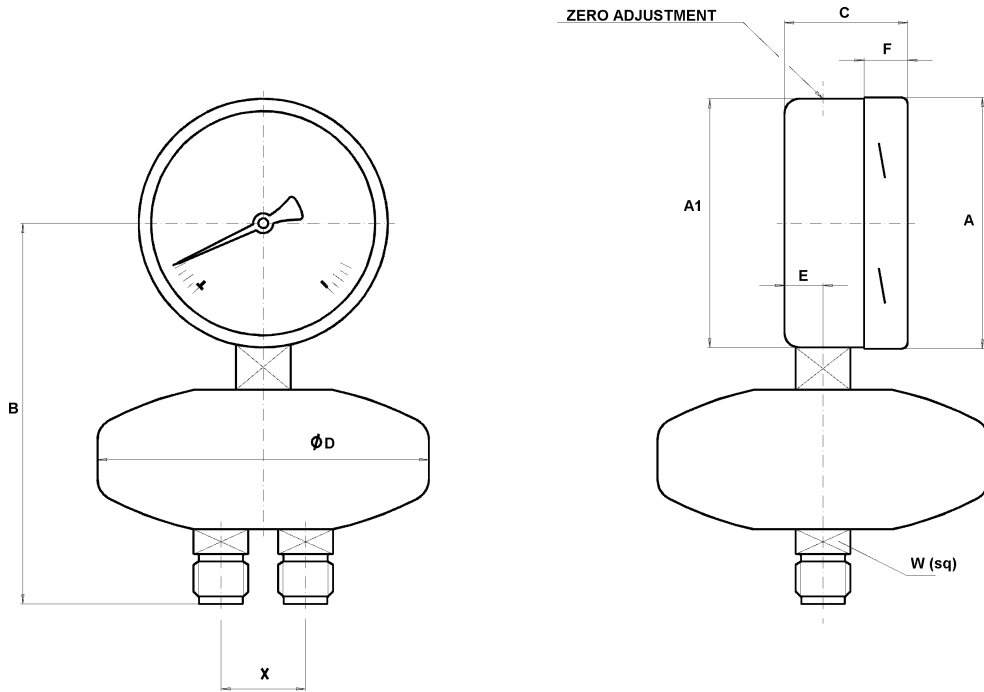

TYPE	WEIGHT	KEY	A	A1	B	C	E	F	T	W	X
736.51 4"	3.74 lb	mm	101	99	170	49.5	15.5	17.5	1/2"	22	37
		in	3.98	3.9	6.69	1.95	.61	.69		.87	1.46
736.51 6"	4.84 lb	mm	161	159	200	49.5	15.5	17.5	1/2"	22	37
		in	6.33	6.25	7.87	1.95	.61	.69		.87	1.46

Design and Operating Principle

- The case (1) is attached to the pressure chamber (2) containing the capsule pressure element (3).
- High pressure ⊕ is applied to the capsule.
- Low pressure ⊖ is applied to the inside of the case.
- Any pressure differential between the high pressure and low pressure side will deflect the capsule pressure element.
- The deflection will be indicated by a pointer on the dial.

Note:

Contacts and transmitters, when installed, are surrounded by the pressure medium. The pressure medium must not affect plastic materials and copper. Contact factory before using electric components with flammable media.

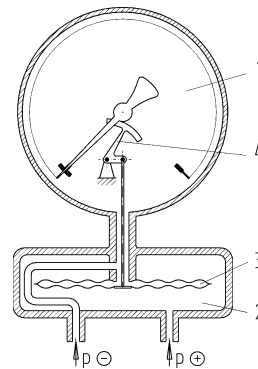

**THE MEASURE OF
Total Performance™**

Ordering Information:

State computer part number (if available) / type number / size / range / connection size and location / options required.

Specifications given in this price list represent the state of engineering at the time of printing. Modifications may take place and the specified materials may change without prior notice



WIKAI Instrument Corporation
 1000 Wiegand Boulevard
 Lawrenceville, Georgia 30043-5868
 Tel: 770-513-8200 Fax: 770-338-5118
<http://www.wika.com> e-mail: info@wika.com