



Pressure Gauges

Application

Measurement of absolute pressure. All stainless steel pressure gauge. Suitable for corrosive environments and gaseous and liquid media. Optional flange connections also available for viscous and contaminated media.

Sizes

4" and 6" (100 and 160 mm)
Type 532.51 available in 6" (160 mm) size only.

Accuracy

Type 532.51: $\pm 0.5\%$ of span (ASME B40.1 Grade 2A)
Type 532.52: $\pm 1.0\%$ of span (ASME B40.1 Grade 1A)
Type 532.53: $\pm 1.5\%$ of span
Type 532.54: $\pm 2.5\%$ of span
Accuracy information for ambient pressure between 28.2 and 31.40 " Hg

Ranges

10 "H₂O to 400 PSI absolute pressure
or equivalent other units of absolute pressure

Working Range

Steady: full scale value
Fluctuating: 0.9 x full scale value

Overpressure Safety

10 x scale range, max 400 PSI. Minimum 15 PSI absolute (atmospheric pressure) with all scale ranges

Operating Temperature

Ambient: -4°F (-20°C) to 140°F (60°C)
Media: max. + 212°F (+100°C)

Temperature error

Additional error when temperature changes from reference temperature of 68°F (20°C) $\pm 0.5\%$ for every 18°F (10°C) rising or falling. Percentage of span.

Weather Protection

Weather resistant (NEMA 4X / IP 54)

Standard Features

Connection (exposed to pressure medium)

Material: 316 stainless steel
Lower mount (LM)
1/2" NPT

Diaphragm Element (exposed to pressure medium)

≤ 5 PSI: 316 stainless steel
> 5 PSI: Duratherm (NiCrCo-alloy)

Pressure Chamber (exposed to pressure medium)

316 stainless steel

Movement

Stainless steel

Dial (exposed to pressure medium)

White aluminum with black lettering

Pointer

Black aluminum, adjustable

Absolute Pressure Gauges

Accuracy $\pm 0.5\%$ of Span • Type 532.51

Accuracy $\pm 1.0\%$ of Span • Type 532.52

Accuracy $\pm 1.5\%$ of Span • Type 532.53

Accuracy $\pm 2.5\%$ of Span • Type 532.54

With Diaphragm Element



Case

Stainless steel case with stainless steel bayonet ring

Window

Laminated safety glass

Gauge Mounting

Mounts to sturdy piping. Additional pipe or wall mounting bracket are available as an option.

Order Options

Liquid filling (Type 533.5X)
Solid-front / blow-out back case (Type 53X.3X)
Overpressure safety in excess of 10 X scale range
Medium temperature in excess of 212°F (100°C)
Pressure connection with DIN or ANSI flange
Pressure connection with vacuum-type flange
Front flange
Rear flange
Pipe or wall mounting bracket (see data sheet AAM 09.07)
4" only: alarm contacts (see data sheet AAE 08.01)
4" only: transmitters (see data sheet AAE 08.02)

Dimensions:

Special DIN Version

Type 532.53 with expanded lower scale range
 Pressure range 0 ... 1020 mbar absolute
 Scale range 0 ... 30 mbar expands over 130°
 Accuracy class 1.6

Operating Principle

Design and operating principle

- The diaphragm (1) separates the pressure chamber (3) and zero reference chamber (2) which represents absolute zero pressure.
- Difference of pressure between pressure chamber (3) and zero reference chamber (2) will deflect the diaphragm (1).
- The diaphragm will come to rest against a contoured metal bolster if the pressure applied is greater than maximum scale value.
- Metal bellows (4) will seal the reference chamber and provide transmission (5) of the pressure applied to the instruments' movement and pointer.

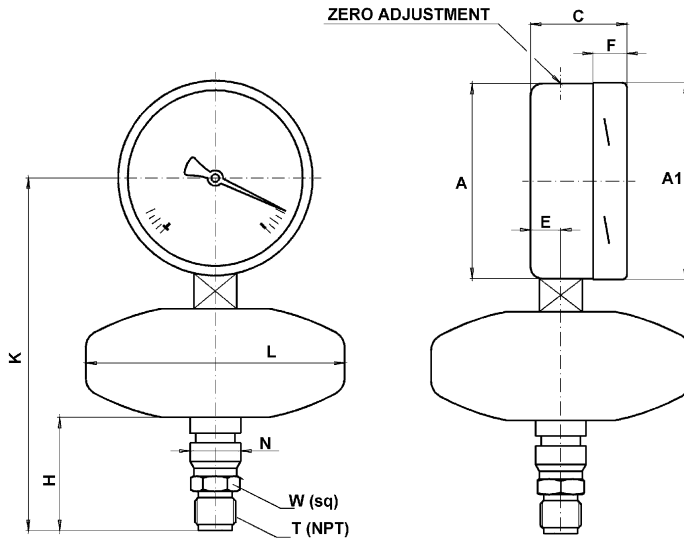
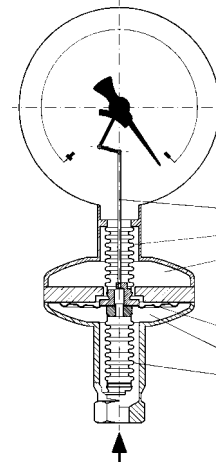

TYPE	WEIGHT	RANGE	KEY	A	A1	C	E	F	K	L	N	T	H	W
532.5X 4"	3.9 lb	</= 6 PSI	mm	99	101	49.5	15.5	17.5	185	133	26	1/2"	58	22
			in	3.9	3.98	1.95	.61	.69	7.28	5.24	1.02		2.28	.87
	2.6 lb	> 6 PSI	mm	99	101	49.5	15.5	17.5	177	76	26	1/2"	66	22
			in	3.9	3.98	1.95	.61	.69	6.9	3.0	1.02		2.6	.87
532.5X 6"	5.1 lb	</= 6 PSI	mm	159	161	49.5	15.5	17.5	215	133	26	1/2"	58	22
			in	6.3	6.34	1.95	.61	.69	8.46	5.24	1.02		2.28	.87
	3.5 lb	> 6 PSI	mm	159	161	49.5	15.5	17.5	207	76	26	1/2"	66	22
			in	6.3	6.34	1.95	.61	.69	8.15	3.0	1.02		2.6	.87

THE MEASURE OF
Total Performance™

Ordering Information:

State computer part number (if available) / type number / size / range / connection size and location / options required.

Specifications given in this price list represent the state of engineering at the time of printing. Modifications may take place and the specified materials may change without prior notice



WIKAI Instrument Corporation
 1000 Wiegand Boulevard
 Lawrenceville, Georgia 30043-5868
 Tel: 770-513-8200 Fax: 770-338-5118
<http://www.wika.com> e-mail: info@wika.com