

Model 142 Electrical Installation and Operating Instructions

ELECTRICAL

Gauges with switches have one or two SPST or SPDT hermetically sealed adjustable set point reed switch assemblies. Resistive load ratings and capabilities for each reed switch type are defined as follows:

Type	SPST	SPDT
*Power	25 W	3W
Max. Current	0.5 Amps	0.25 Amps
Max. Voltage	240 VAC/VDC	125 VAC/VDC
Setting (F.S.)	15% to 95%	15% to 95%
Hysteresis (Max/Nom)	15% / 8% Full Scale(F.S.)	10% / 5% Full Scale(F.S.)
Repeatability	1% F.S.	1% F.S.

* Product of the switching voltage and current shall not exceed the power rating of the device.

Provide standard protection techniques for the switch contacts for capacitive and inductive loads. Use current limiting techniques near the switch to protect the contacts due to high inrush (i.e.; in line resistor or inductor) for long cable interfaces. Provide clamping devices at or near inductive loads (i.e.; relay). Long cable runs can be considered both inductive and capacitive, therefore also clamp across the switch. We recommend for long cable runs of 70 feet or greater that you use the SPST switch or use a current limiting resistor wired in series and located near the switch. Contact the factory if you need assistance.

Both switch types are field adjustable from 15% to 95% of full scale reading of the gauge.. All switches come with a decal to identify adjustment direction to increase the set point. To set the switch at a desired set point on increasing pressure apply pressure to the gauge for the desired set point. Adjust the switch so that it is adjusted above the set point (normally open contacts are open) and slowly decrease the set point until the switch activates (normally open contact closes). Remove pressure and slowly reapply to determine the actual setting. This process can be repeated to achieve a more accurate setting.

All switch functionalities shown are with the gauge at 0 PSID. The SPST switches are available in the Normally Open configuration only.

Use the Mid-West Power Relay 1000TR or equivalent relay for loads above the switch rating.

The following warnings apply to all gauge options with electrical interface.



WARNING: ELECTRICAL CONNECTIONS SHOULD BE PERFORMED BY QUALIFIED PERSONNEL AND MEET THE REPRESENTATIVE COUNTRY'S NATIONAL ELECTRICAL CODE.

WARNING: FAILURE TO CONNECT TO THE PROTECTIVE CONDUCTOR TERMINAL MAY RESULT IN A SHOCK HAZARD.

WARNING: REMOVAL OR REPLACEMENT OF INSTRUMENT HARDWARE VOIDS ALL WARRANTIES AND CONFORMANCES TO ANY STANDARDS (EXCEPT COVERS AND OR SWITCH ADJUST PLUGS).

NEMA 4X (Weatherproof Enclosure)
(A, B, E, & F options)



The reed switch(es) are located inside the enclosure, on the top of the pressure housing, and are connected to a 7 position terminal strip. An opening is provided at the rear of the enclosure for a 1/2" flexible weather-proof cable or conduit connector (supplied by customer) (A & B Option) or a 1/2" FNPT conduit interface (E & F option). Upon request the hole may be sized to accommodate a PG-11 cable gland connector (A & B Option).

Electrical Configurations E & F are CSA Certified to both Canadian & US standards for use in Class I, Div II, Groups A, B, C, & D; Class II, Div II, Groups F & G Hazardous Locations.

Remove the switch enclosure cover by removing the (4) screws. Insert wires through an appropriate (not supplied) weatherproof connector into the enclosure and connect to the terminal strip per the terminal strip diagram shown below or on the underside of the switch enclosure cover. The center connection is for connection of a protective conductor and is connected to the body of the pressure gauge.

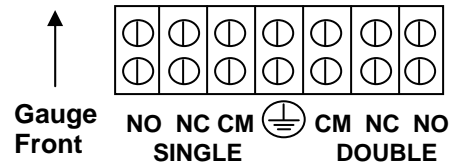

The terminal strip will accept wires in the range of 22 Awg - 16 Awg.. Reinstall the cover, gasket, and (4) screws. (Fig. 3) after connection of field wiring.

Wiring for the SPST switches is connected between NO and CM connections on the terminal strip. Normally closed switches are not available.

Access holes and plugs are provided for external adjustment of the switches if required.

Transmitter Option: ('T' or "W" Electrical Configuration)

The Model 142 Transmitter is intended for use in General Purpose Locations (T electrical configuration) or Division 2 locations (W electrical configuration). In both cases the enclosure carries a NEMA 4X IP65 environmental rating.

The transmitter assembly as a component has passed numerous European EMC standards (ie; Compliance to IEC EN61326). Contact the factory if additional low pass filtering is necessary.

The Model 142 indicating / non-indicating differential pressure transmitter is a 2 wire loop powered microprocessor based 4-20 ma transmitter. The magnetic angle sensor & electronics senses the angle (relative to the transmitter sensor) of the magnet which moves linearly in the bore. Each transmitter is individually calibrated to the gauge using an 11 point calibration linearization technique. This method results in a <2% full scale accuracy for the upper 80% of the range.

In addition an external zero pin is available for simple remote zeroing (instead of supplied local zero) after installation.

Caution:
Do not attempt to reposition the transmitter assembly within the enclosure. This voids the warranty and will "knock" the unit out of calibration. Disassembly and re-assembly of any internal process parts will also require the unit to be re-calibrated. Calibration must be performed at the factory.

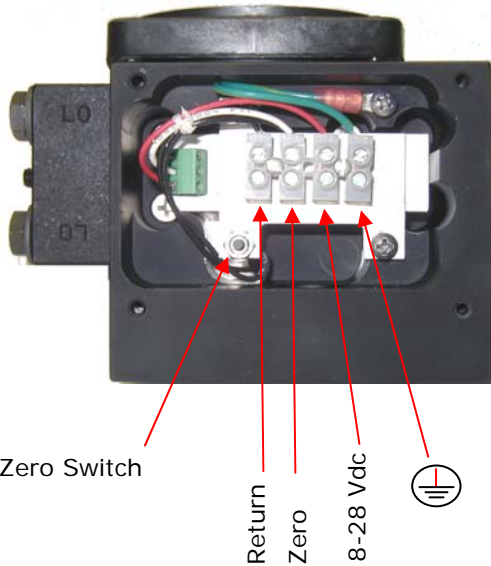

Figure 4

The weather-proof enclosure comes standard with a 1/2" FNPT conduit interface. Internal to the enclosure is a 4 position terminal strip. The terminal strip accepts wire sizes 22 AWG – 16 AWG. Connections are defined in Figure 4.

Connect loop power between the connections labeled 8-28 Vdc and RTN. Connect the protective conductor wire to the terminal with the \oplus symbol. A zero pushbutton is also included. Zero the transmitter with the transmitter powered and no differential pressure applied by depressing the switch for a minimum of 2 seconds.

The maximum loop resistance is 1000 ohms (@ 28Vdc Input). Use the following formula to determine the maximum loop resistance at other input voltages:

$$((V_s - 8) * 1000) / 20$$

Interface Schematic

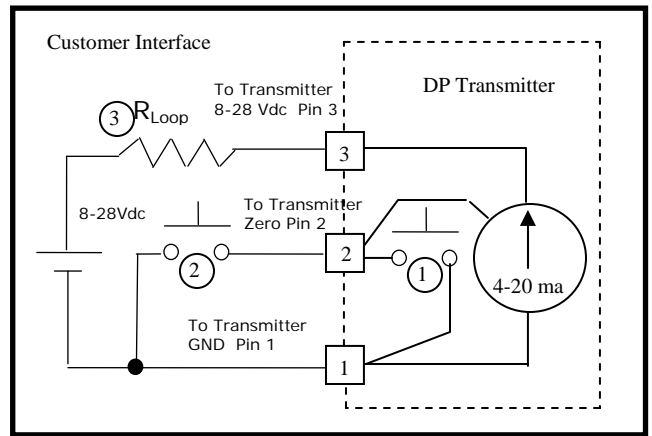

- ① Zero switch not present for hazardous locations product
- ② Optional remote zero (customer supplied)
- ③ Loop Resistor can be located in the ground leg

The interface schematic shows an implementation of the Remote Zero function. The supplied unit incorporates an internal pushbutton for zeroing the unit locally (non-hazardous locations only).

Occasionally the transmitter may require a "re-zero" . The "re-zero" may be necessary due to stray magnetic fields or a large change in temperature from when the unit was originally calibrated.

Warning: If zeroing in the Hazardous Location environment use a switch approved for that location.

Trouble Shooting

A. Switch doesn't function. (Assuming Indication is good)

1. Make sure that the switch load does not exceed the specified wattage rating of the switch. (steady-state and transient). Contact factory for assistance for excessive loads, otherwise proceed to the next step.
2. Perform a continuity check of the switch contacts by trying to actuate the switch using an external magnet. An operational switch usually indicates a problem with the gauge. If not operational proceed to the next step.
3. Verify the reed switch wires are connected to the terminal strip (NEMA 4X enclosure only). Contact the factory for assistance if the switch is connected and/or request an "RGA" number.

B. Transmitter doesn't function

1. Make sure you have supplied power (proper voltage) to the unit.
2. Check that you are wiring to the correct Interface terminals.
3. Check the transmitter interfaces to the terminal board for loose connections.

4. Make sure that the loop resistance does not exceed the specified rating.

C. Gauge accuracy and set point problems:

1. Verify gauge is not in an electromagnetic / magnetic environment. i.e.; close proximity to high current power lines.
2. All others, contact the factory for assistance.

D. When contacting the factory please have the following information available if possible:

1. Gauge / Switch Serial Number
2. Model Number of the Gauge / Switch
3. Description of the problem and events prior to failure.
4. Interface Information such as switching voltage, switching current, cable lengths, etc

Transmitter Specifications: (Calibrated on Increasing pressure)				Comments:
Differential Pressure Range	0-20" H ₂ O to 0 -25 PSID			
Leakage	None Hi to Lo			
Pressure (Ratings)				
Max Working	See Specifications			
Gauge Accuracy	2%			ASME B40.100 GRADE B
Operating Temperature (Max.)	-20° F - 150° F			
ELECTRICAL:				
	Min	Typ	Max	
Transmitter Accuracy (FSR)			2%	Upper 80% of Full Scale Range
Supply Voltage (3) (Vdc)	8		28	Pin 3 Reverse Polarity Protected
Output Current (ma)				
Zero Floating (2)	4.0 – 20.1 ma	4.0 – 21.0	4.0 – 22.0	Pin 2
Zeroed (1 connected to 2)		8		
Voltage (Pin 2 to 1)	4.8		6.3	
Zero Time (seconds)	2			
Max Loop Resistance (ohms)			1000	
Max Loop Resistance Formula	$((V_s - 8) * 1000) / 20$			
INTERFACE:				
Electrical:				
Connections:	4 Position Terminal Strip; ½" NPT Conduit 1= Rtn, 2= Zero, 3 = 8-28 Vdc In 4= Chassis			22 Awg – 16Awg Wire
Environmental Rating:	NEMA 4X			
Certifications:	CSA (Canadian & US Standards; Division 2 Locations)			

DIMENSIONAL INFORMATION

ELECTRICAL CONFIG: A & B

4 1/2" DIAL
NEMA 4X / IP66 HOUSING

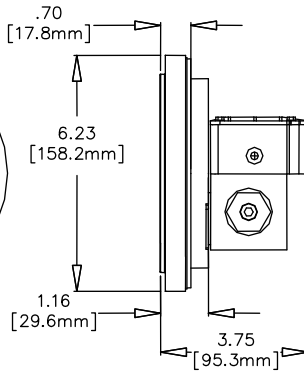
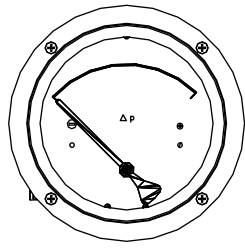

WEATHER PROOF ASSY.
1 OR 2 SWITCHES
(OPTIONAL)

.88 (22.3) DIA. THRU
CORD/CONDUIT
CONNECTOR ENTRY
OPTIONAL: .73 (18.5) DIA. THRU
FOR PG-11 CABLE GLAND

CORD / CONDUIT
LOCKING NUT MAX
DIAMETER ACROSS FLAT
1.08 (27.4)

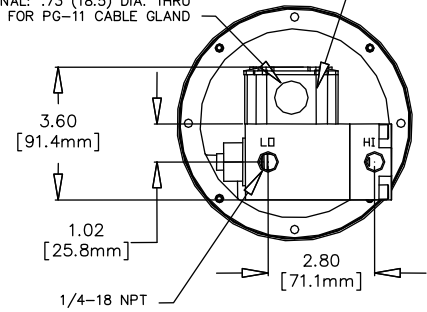

ELECTRICAL CONFIG: A & B

2 1/2" DIAL
NEMA 4X / IP66 HOUSING

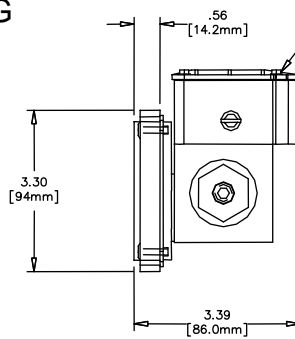

.88 [22.3mm] DIA. THRU
CORD/CONDUIT
CONNECTION ENTRY

WEATHER PROOF SWITCH ASSY.
1 OR 2 SWITCHES (OPTIONAL)

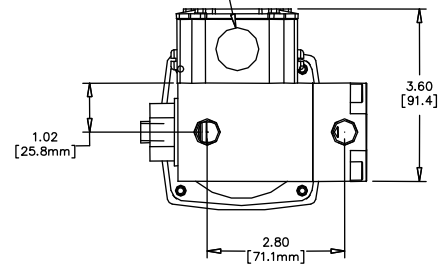

ELECTRICAL CONFIG: E & F

4 1/2" DIAL
NEMA 4X / IP66 METAL HOUSING



2 1/2" DIAL
PICTURED

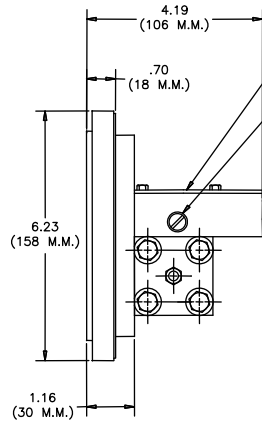
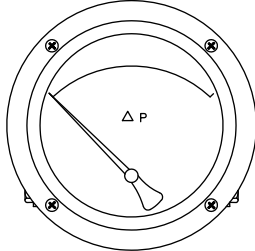

WEATHER PROOF SWITCH ASSY.

SWITCH
ADJUST

1/2" NPT CONDUIT ENTRY

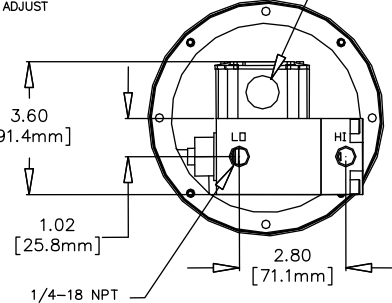

ELECTRICAL CONFIG: T & W:

Transmitter 4 1/2" & 2 1/2" DIAL
NEMA 4X / IP66 METAL

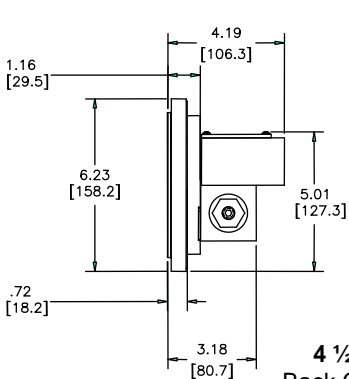

4 1/2" DIAL
Back Connected

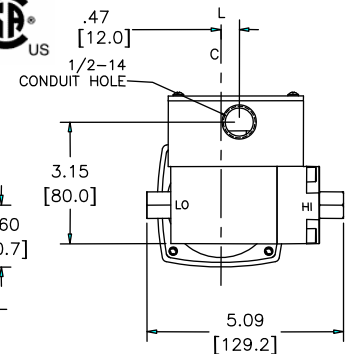
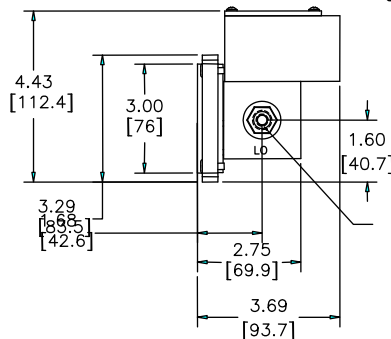
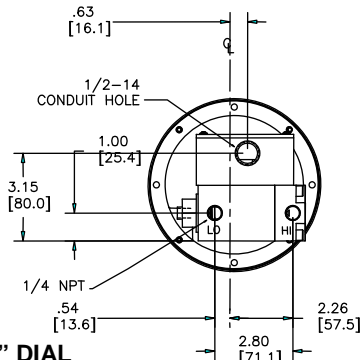

2 1/2" DIAL
End Connected

PROOF PRESSURE: 2X Working Pressure

Warranty: 5 years Transmitter: (1 Year)

TEMPERATURE LIMITS: -40 °F (-40° C) to 200°F (93°C) (Switch Options); -20°F (-28°C) To 150 °F (65°C (Transmitter Option). These limits are based on the entire instrument being saturated to these temperatures. System (process) temperatures may exceed these limitations with proper installation. Contact our customer service representative for details.

STANDARDS: All Model 142 Series differential pressure gauges either conform to and/or are designed to the requirements of the following standards:

ASME B1.20.1	NACE MR0175
ASME B40.1	NEMA Sts. 250
EN-61010-1	UL Std. No. 50, 508, & 1604
CSA-C22.2 No. 14, 25, & 213	

CE Marking Statements:

The Electrical Configurations A,B, E, & F of this product are CE marked in compliance with the Low Voltage Directive to EN-61010-1.

These products shall not be placed in an Explosive atmosphere as defined by the ATEX Directive 94/9/EC except if evaluated to be "Simple Apparatus".

They may be classified as simple apparatus. However, the evaluation to the relevant portions of the applicable standards and clearly identifying the product as simple apparatus shall be the responsibility of the end user.

The Pressure Equipment Directive has been determined to be **non applicable for CE marking**. These products are manufactured in accordance with article 3, paragraph 3 of the directive, "sound engineering practice". They fall below category I for non-hazardous gases, hazardous liquids, & non-hazardous liquids. This product also falls below category I for hazardous gases at or below 200 bar.

Simple Apparatus NEC 504.2

The A, B, E, & F Electrical configurations of this product meet the simple apparatus definition as defined in NEC 504.2 of Article 504 (Intrinsically Safe Systems). Because of this classification, equipment listing is not required (504.4) and ordinary wiring methods shall be permitted (504.20). Proper installation of this product in a hazardous location to the applicable requirements is the responsibility of the end user / equipment installer.

EMC Directive:

The transmitter design has been evaluated to and passed the following "EN" Standards as they relate to the EMC directive. However, the units are not CE marked for compliance to the EMC directive.

IEC EN61326:1997 Environment Industrial, Electrical Equipment for measurement, Control and Laboratory use, EMC requirements from which:

EN55011:1998 Emission standard for Industrial, Scientific and Medical Equipment, Class A
EN61000-4-2:1995 Electrostatic discharge (ESD) immunity
EN61000-4-3:1996 Radiated EM field immunity
ENV50204:1995 Radiated EM field immunity from digital telephones (GSM)
EN61000-4-4:1995 Electrical fast transient (EFT) immunity
EN61000-4-5:1995 Surge immunity
EN61000-4-6:1996 RF conducted immunity
EN61000-4-8:1993 Power Frequency magnetic field

Warning: The suitability of the application and installation of this differential pressure switch / transmitter is the responsibility of the end user. The applicable certifications, listings apply to the differential pressure switch / transmitter only.

Mid-West[®]

Instrument

6500 Dobry Dr. Sterling Heights, MI 48314

Ph: (586)254-6500 FAX (586)254-6509

E-Mail: sales@midwestinstrument.com

Web Page: www.midwestinstrument.com