

## Model 121 Indicating Differential Pressure Switch / Transmitter Electrical: Installation and Operating Instructions

### INSPECTION

Upon receipt of your order, please review the Model Number Tag to verify that the model number and the electrical ratings match the product that you ordered.



FIGURE 1



### ELECTRICAL

**WARNING: ELECTRICAL CONNECTIONS SHOULD BE PERFORMED BY QUALIFIED PERSONNEL AND MEET THE REPRESENTATIVE COUNTRY'S NATIONAL ELECTRICAL CODE.**

**WARNING: FAILURE TO CONNECT TO THE PROTECTIVE CONDUCTOR TERMINAL MAY RESULT IN A SHOCK HAZARD.**

### Switch Options:

Gauges with switches have one or two hermetically sealed adjustable set point reed switch assemblies. Load ratings and capabilities for each switch type are defined as follows:

#### REED SWITCH RATINGS (Resistive Load)

Type	SPST	SPDT
Option:	E, F, G	A
*Power	60 W	3W
Max. Current	3.0 Amps	0.25 Amps
Max. Voltage VAC/DC	240	125
Setting (%F.S.)	20 to 95	15 to 95
Hysteresis (Max/Nom) (F.S.)	18% / 10%	12% / 8%
Repeatability	1% F.S.	1% F.S.

\* Product of the switching voltage and current shall not exceed the power rating of the device.

The SPDT switch ('A' Electrical Option) and associated functionality at '0' PSID is shown in Figure 2. SPST switches ('E', 'F', or 'G' Electrical Options) may be normally closed or normally open at '0' PSID dependent upon the option specified on the purchase order.

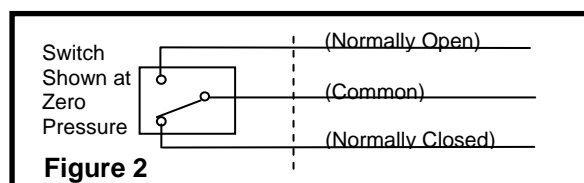

Figure 2

All switch types are field adjustable. The defined range of the adjustment is specified in the table above. All switches come with a decal to identify adjustment direction to increase the set point. **Do not use excessive force when rotating the adjustment screw as the adjustment mechanism may be damaged. Also note the location of the screw adjust (See Figure 3.) Do not mistake it for the calibration adjust for the gauge.**

**Note:** Switches can be set below the defined minimum set point however, the switch may not remain activated at maximum PSID. If the unit is set below the defined minimum set point, the customer should verify that the switch remains activated from the set point to over range of the gauge.

Provide standard protection techniques for the switch contacts for capacitive and inductive loads. Use current limiting techniques near the switch to protect the contacts due to high inrush (i.e.; in line resistor or inductor) for long cable interfaces. Provide clamping devices at or near inductive loads (i.e.; relay). **Maximum wire length between the 3W switch and its load, should not exceed 70 – 100 feet for 120 VAC applications.** Contact the factory for assistance regarding this condition.

### Switch Interface

The reed switch(es) are located inside the enclosure, on the top of the pressure housing, and are connected to a 7 position terminal strip (See Figure 3). An opening is provided at the bottom of the gauge body for a 1/2" FNPT conduit interface.

Remove the switch enclosure cover by removing the (4) screws. Insert field wires through the conduit entry, into the enclosure, and connect to the terminal strip per the terminal strip diagram shown below or on the underside of the switch enclosure cover. The center connection is for connection of a protective conductor and is connected to the body of the pressure gauge.

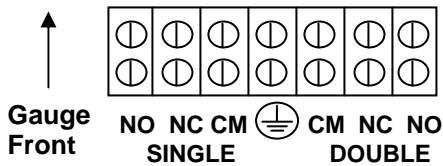

The terminal strip will accept wires in the range of 22 Awg - 16 Awg.. Reinstall the cover, and (4) screws after connection of field wiring.

Wiring for the SPST switches are connected either between NO and CM connections or NC and CM on the terminal strip dependent on the functionality ordered.

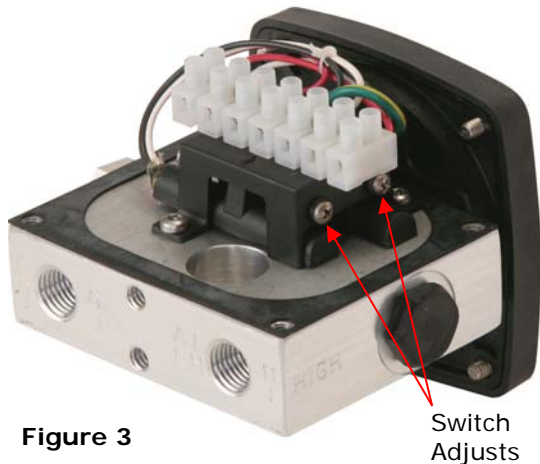

**Figure 3**

Switches for dual switch assemblies are independently adjustable. Rotate adjust screw CCW to increase the set point(s). If setting the switch near the maximum set point, please ensure the wires do not get pinched between the gauge body and the switch cover.

**Transmitter Option:**



The Model 121 Transmitter is intended for use in General Purpose (T Electrical Configuration) or Division 2 locations (W Electrical Configuration) In both cases the enclosure carries a NEMA 4X environmental rating.

The transmitter assembly as a component has passed numerous European EMC standards (ie; Compliance to IEC EN61326). Contact the factory if additional low pass filtering is necessary.

The Model 121 indicating / non-indicating differential pressure transmitter is a 2 wire loop powered microprocessor based 4-20 ma transmitter. The magnetic angle sensor & electronics senses the angle (relative to the transmitter sensor) of the magnet which moves linearly in the bore. Each transmitter is individually calibrated to the gauge using an 11 point calibration linearization technique. This method results in a <2% full scale accuracy for the upper 80% of the range.

In addition an external zero pin is available for simple remote zeroing (instead of supplied local zero) after installation. A zero switch is not supplied for the Hazardous locations option.

**Caution:**

Do not attempt to reposition the transmitter assembly within the enclosure. This voids the warranty and will "knock" the unit out of calibration. Disassembly and re-assembly of any internal process parts will also require the unit to be re-calibrated. Calibration must be performed at the factory.

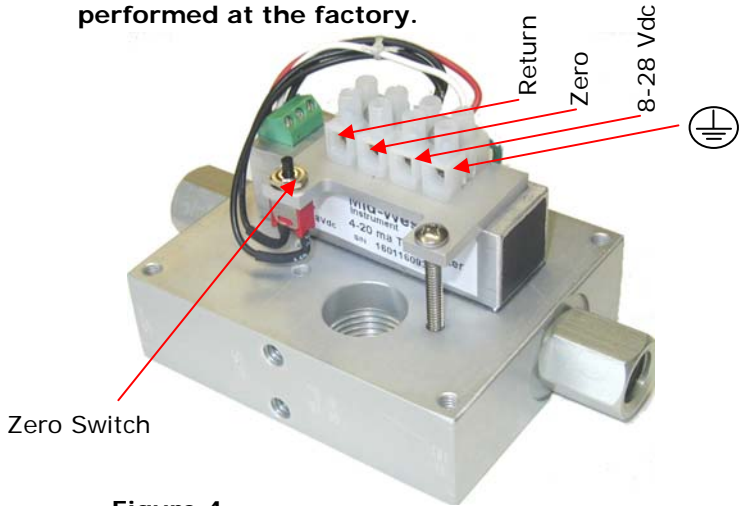

**Figure 4**

The weather-proof enclosure comes standard with a 1/2" FNPT conduit interface. Internal to the enclosure is a 4 position terminal strip. The terminal strip accepts wire sizes 22 AWG – 16 AWG. Connections are defined in Figure 4.

Connect loop power between the connections labeled 8-28 Vdc and RTN. Connect the protective conductor wire to the terminal with the ground symbol. A zero pushbutton is also included. (only for non hazardous location product "T" configuration.) Zero the transmitter with the transmitter powered and no differential pressure applied by depressing the switch for a minimum of 2 seconds.

The maximum loop resistance is 1000 ohms (@ 28Vdc Input). Use the following formula to determine the maximum loop resistance at other input voltages:  $((Vs - 8) * 1000) / 20$

**Interface Schematic**

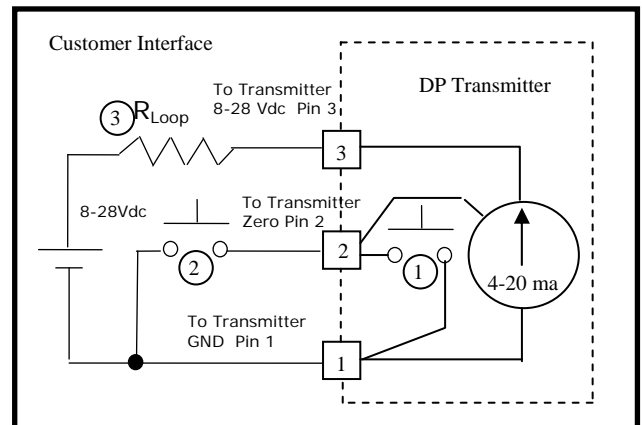

- ① Zero switch not present for hazardous locations product
- ② Optional remote zero (customer supplied)
- ③ Loop Resistor can be located in the ground leg



## **Division II Hazardous Ratings (Options E, F, W):**

The **E, F, & W** Electrical Configurations are 3<sup>RD</sup> party certified for **Class I, Division 2, Groups A, B, C, & D; Class II, Division 2, Groups F & G** hazardous environments. Product shipped with the CSA mark, identifies that the product has been tested to the applicable **US standards** and the applicable Canadian standards.

## **INSTALLATION**

### **Tools Required:**

**Phillips Screwdriver**  
**Adjustable or 11/16" wrench (for end connected process connections)**  
**Small Slotted head Screwdriver**

**CAUTION: DO NOT EXCEED THE MAXIMUM RATED WORKING PRESSURE STATED ON THE ID STICKER.**

**CAUTION: ALWAYS USE A WRENCH ON THE SWITCH'S PROCESS CONNECTIONS TO KEEP THEM IN PLACE WHILE TIGHTENING AND LOOSENING CUSTOMER SUPPLIED PROCESS FITTINGS.**

**Warning: IF ZEROING IN THE HAZARDOUS LOCATION ENVIRONMENT USE A SWITCH APPROVED FOR THAT LOCATION.**

Model 121 Series Transmitter is calibrated and tested prior to shipment and is ready for immediate installation. Use of the following installation procedures should eliminate potential damage and provide optimum trouble-free operation

## **CONNECTIONS**

1/4" FNPT are provided as standard for the Model 121. There are two connections on the housing identified as "High" and "Low" for high pressure and low pressure (Fig. 5). Be sure these get plumbed to the proper connections on your system. Improper connection will not damage the instrument, but it will not function properly. Flexible tubing is recommended to minimize the effect of any vibration that may exist.

On liquid service the instrument should be mounted

Connections to the terminal strip were identified in the previous section. The terminal strip is compatible for wire ranges from 16-22 AWG.

**below** the process connections to facilitate self bleeding. On gas service it should be located **above** the process connections to promote self-draining. If the process contains particulates, a "pigtail" loop or drop leg (manometer "U-tube" configuration) in the tubing will minimize the possibility of it migrating into the instrument.

An optional pipe mounting kit is available for mounting the gauge to a 2" vertical or horizontal pipe.

## **TROUBLE SHOOTING**

### **1. Gauge does not indicate differential.**

- A. Check for proper hook up, high to "hi" and low to "lo".
- B. Make certain block valves are open and, if using a 3-valve manifold, that the equalizer (balance) valve is closed.
- C. If A & B check out correctly, loosen or disconnect the high pressure line to determine if there is pressure to the instrument.
- D. If there is pressure to the instrument, check to determine that there is differential across the unit being monitored. If so, contact the factory for assistance and/or an "RGA" (return goods authorization) number to return the instrument for repair or replacement.

### **2. Transmitter doesn't function**

- A. Make sure you have supplied power (proper voltage) to the unit.
- B. Check that you are wiring to the correct Interface terminals.
- C. Check the transmitter interfaces to the terminal board for loose connections.
- D. Make sure that the loop resistance does not exceed the specified rating.

### **3. Gauge / Transmitter accuracy and set point problems:**

- A. Verify gauge is not in an electromagnetic / magnetic environment. i.e.; close proximity to high current power lines.
- B. All others, contact the factory for assistance

# TRANSMITTER SPECIFICATIONS

Transmitter Specifications: (Calibrated on Increasing pressure)				Comments:
Differential Pressure Range	0-5 PSID to 0 -100 PSID			
Leakage	15SCFH @100 PSID Max Hi to Lo			
Pressure (Ratings)				
Max Working	6000 PSIG			
Gauge Accuracy	2%			ASME B40.100 GRADE B
Operating Temperature (Max.)	-20° F - 150° F			
<b>ELECTRICAL:</b>				
	<b>Min</b>	<b>Typ</b>	<b>Max</b>	
Transmitter Accuracy (FSR)			2%	Upper 80% of Full Scale Range
Supply Voltage (3) (Vdc)	8		28	Pin 3 Reverse Polarity Protected
Output Current (ma)				
Zero Floating (2)	4.0 – 20.1 ma	4.0 – 21.0	4.0 – 22.0	Pin 2
Zeroed (1 connected to 2)		8		
Voltage (Pin 2 to 1)	4.8		6.3	
Zero Time (seconds)	2			
Max Loop Resistance (ohms)			1000	
Max Loop Resistance Formula	$((V_s - 8) * 1000) / 20$			
<b>INTERFACE:</b>				
Electrical:				
Connections:	4 Position Terminal Strip; ½" NPT Conduit 1= Rtn, 2= Zero, 3 = 8-28 Vdc In 4= Chassis			22 Awg – 16Awg Wire
Environmental Rating:	NEMA 4X			
3 <sup>rd</sup> Party Certifications:	Class I, Division 2, Groups A,B,C,D; Class II, Division 2 Groups f & G			

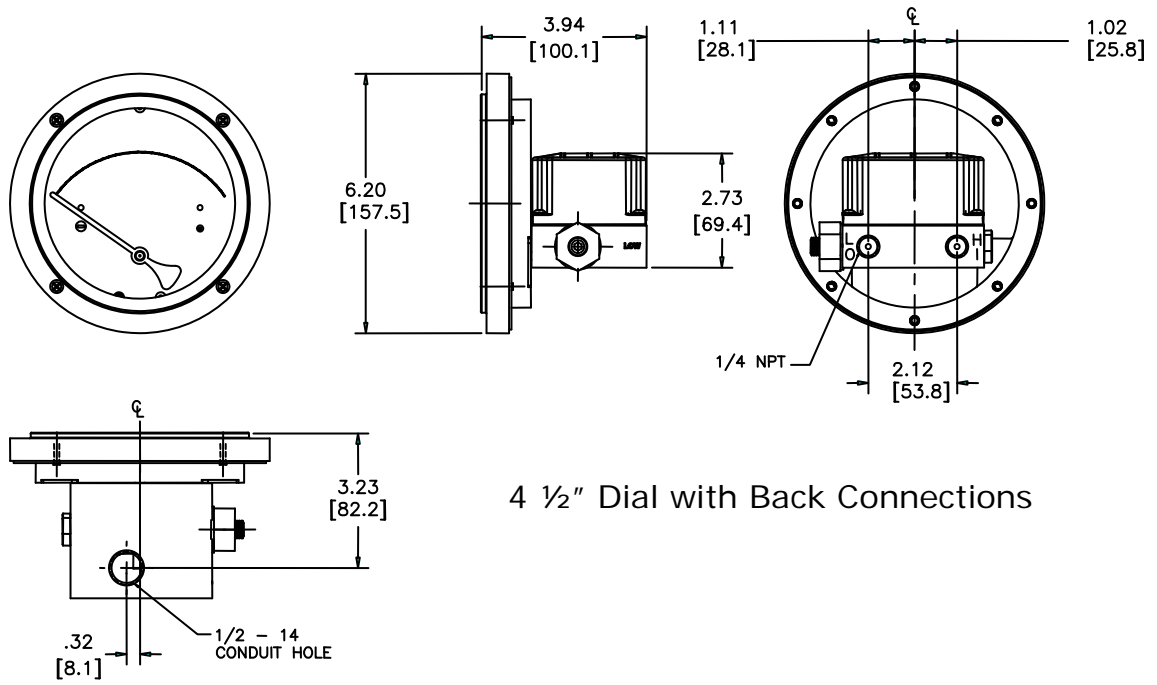

4 1/2" Dial with Back Connections

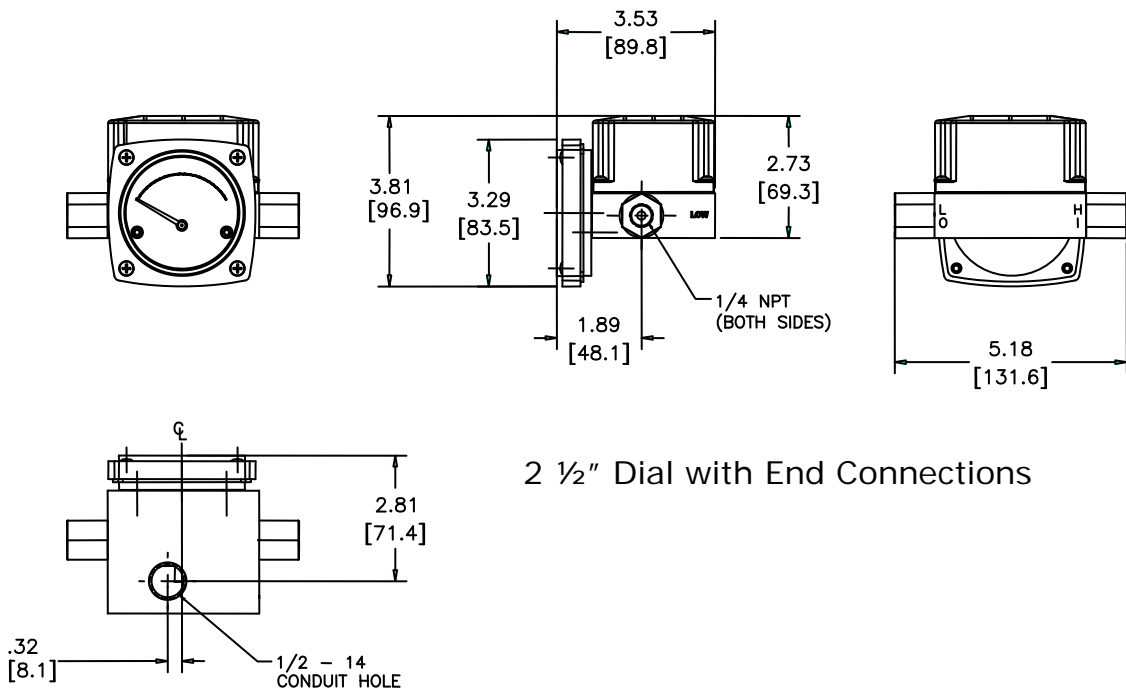

2 1/2" Dial with End Connections

Figure 5