

Model 120 Series "Filter Minder"[®] Piston-Type Differential Pressure Gauge

MEDIUM RANGE: 0-5 P.S.I.D. to 0-110 P.S.I.D. (0.35 to 7.0 bar)

A low cost differential pressure gauge for use in measuring the pressure drop across filters, strainers, separators, valves, pumps, chillers, etc., and for local flow indication and control.

- Simple, rugged, compact design.
- Working pressure 6000 P.S.I.G. (400 bar) models 120-A and 120-S.
- Working pressure 5000 P.S.I.G. (340 bar) models 120-M and 120-N.
- Over-range protection to max. pressure.
- Aluminum or 316 stainless steel housing with 316 stainless steel internals.
- Monel or Aluminum Bronze housing with monel internals.
- Weather-resistant construction standard.
- Accuracy $\pm 3-2-3\%$ full scale (ascending).
- Shatter resistant lens.
- More cost effective and more accurate than using two pressure gauges in monitoring differential pressure.
- 2-1/2" and 4-1/2" plastic dial assemblies.

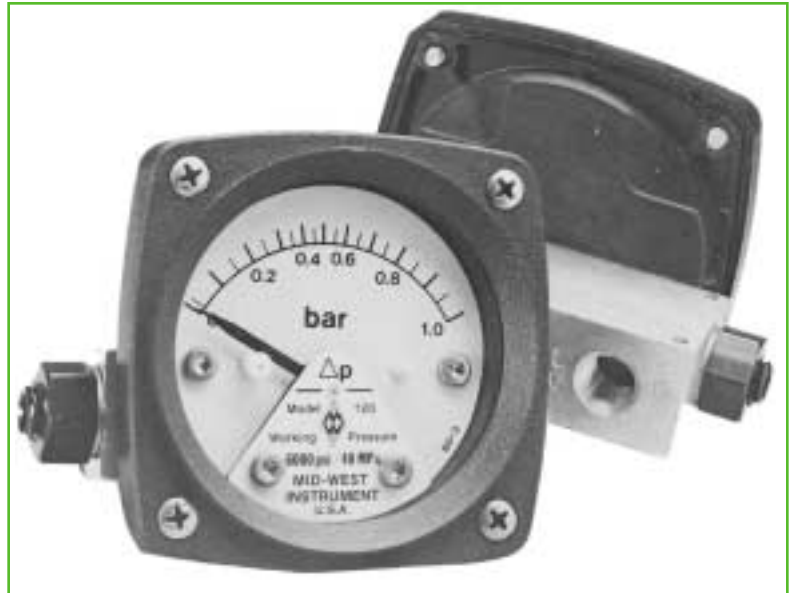

2-1/2" Plastic Dial Assy.

- 3-1/2" and 4-1/2" anodized aluminum dial assemblies.
- Uni-directional or bi-directional.
- Five Year Limited Warranty



4-1/2" Plastic Dial Assy

Differential pressure is sensed by the movement of a floating piston magnet against a calibrated spring. The gauge pointer, outside the pressure housing, follows the movement of the piston magnet and indicates differential pressure.

Available with magnetically actuated hermetically sealed CSA listed reed switches to provide high and low limit alarm or control.

An optional maximum indication follower pointer provides automatic indication of maximum differential occurring during a time period or system cycle.

Reversed pressure ports are optionally available to facilitate installation and readability depending on which side of a filter, etc., the instrument must be installed.



2-1/2" Plastic Dial Assy. w/Max.
Follower Pointer

Why use a dp gauge like this, instead of one or two pressure gauges to monitor a filter? Let's take a typical filter application – 1000 P.S.I.G. system pressure and 25 P.S.I.G. maximum dp. Two 1% accuracy pressure gauges (0-2000 P.S.I.G.) could have a combined error of ± 40 P.S.I.G. (more than the maximum allowable dp!) A 0-50 P.S.I.D. Model 120 would have an error of ± 1 P.S.I. at a reading of 25 P.S.I.D., **40 times the accuracy of more costly pressure gauges!**

NOTE: Due to precision sizing of piston and body bore, leakage across the piston will not exceed 15 SCFH air at 100 P.S.I.D. at ambient conditions.



Cutaway View w/1/4" FNPT Back Connections

Model 120 "Filter Minder"[®] Differential Pressure Gauge with Control Switching

The Model 120 "Filter Minder"[®] gauge is available with one or two hermetically sealed reed switches. The switches are adjustable (see table for adjustment range) within a defined percentage of the full scale range of the gauge and are available in SPDT and SPST, normally open or normally closed configurations for various load power ratings. The switches can be set to activate or deactivate on rising or falling pressure.

All hazardous location switches are CSA & UL Listed. The CSA & UL listings are for the entire design and not just the enclosure. All standard and weatherproof units are CE marked for conformance with the Low Voltage Directive to harmonized standard EN 61010-1.

The standard reed switch is enclosed in a weather-resistant plastic housing. Adjustment of the switch setting is made with an external screw adjustment.

The switch functionality will be different for gauges with bi-directional operation for positive and negative delta pressure. For example a SPDT switch with positive ΔP applied to the gauge, the red wire will be N.O. and the black will be N.C.. For negative ΔP the functionality will be reversed.



Standard Enclosures for two (2) Switches
w/1/4" FNPT Conduit Connection.
Nema 4X/IP65

Location for a single SPDT (grommet or conduit) switch will be on the bottom of the gauge body for a normal port and on the top for a reverse port. Locations for a single SPST (grommet or conduit) N.O. or SPST N.C. switch will be on the bottom and top respectively for a normal port gauge. The locations will be reversed for a reverse port gauge. For more details request IM 120/latest.

A non-indicating (no dial) differential pressure switch is also available.

Special Switch Enclosures

- 1 Hazardous Locations Division 1:**
CSA & UL listed design with SPST or SPDT switches in NEMA 7/9 enclosure approved for use in Class 1 Division 1, Groups C & D; Class 2, Division 1, Groups E, F, & G atmospheres.
- 2 Hazardous Locations Division 2:**
CSA & UL listed design with SPST or SPDT switches in a general purpose enclosure approved for use in Class 1, Division 2, Groups A, B, C, & D; Class 2, Division 2, Groups F & G atmospheres.
- 3 Weatherproof:**
Switch(es) and gauge are enclosed in a non-corrosive, molded, plastic enclosure that are oil-tight, dust-tight, and water-tight per NEMA 4X. Design is CE marked for conformance to the Low Voltage Directive.

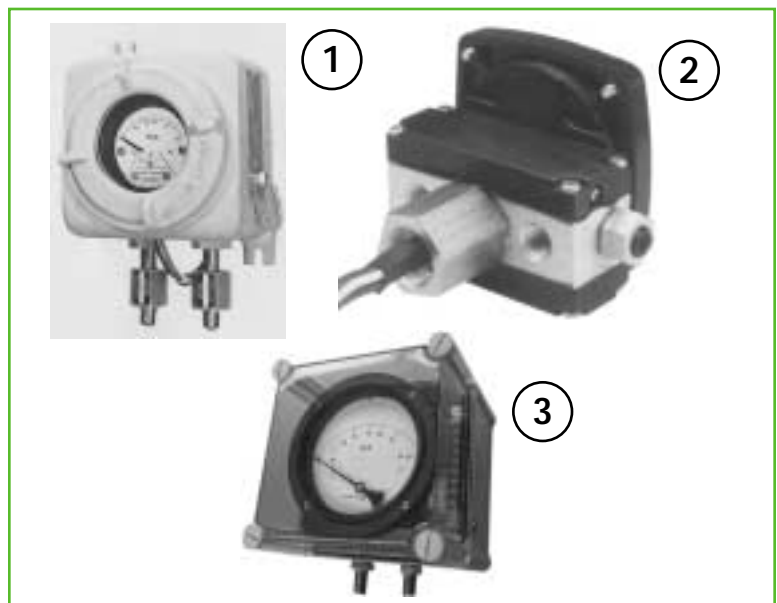

Reed Switch Ratings (Resistive Load)

Type	SPST	SPST	SPDT	SPDT
Option:	B,C,D***	E,F,G	H	A
*Power	50 W	60 W	60 W	3 W
Max. Current	0.5 Amps	3.0 Amps	1.0 Amps	0.25 Amps
Max. Voltage VAC/VDC	240	240	240	125
**Setting (%F.S.)	10 to 100	25 to 95	25 to 100	10 to 90
Hysteresis (Max/Nom)	10% / 2% (F.S.)	15% / 8% (F.S.)	20% / 13% (F.S.)	10% / 5% (F.S.)
Repeatability	1% F.S.	1% F.S.	1% F.S.	1% F.S.
Leads 22 Awg.	(2), 24"	(2), 24"	(3), 24"	(3), 24"

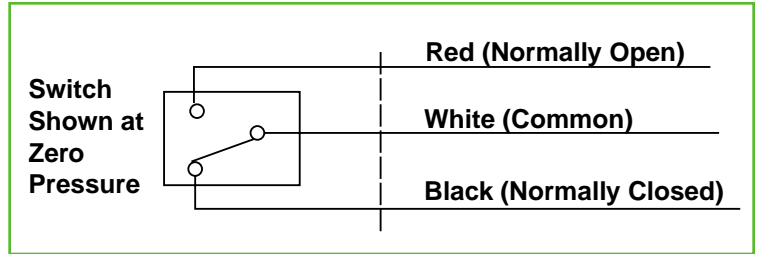

*Product of the Switching Voltage & Current shall not exceed power rating of the device.

**Except where otherwise noted.

***B, C, & D options are available, however they are not identified in Electrical Specifications. (Recommend using E, F, or G)

STANDARD MODEL SPECIFICATIONS

120-AA-00-00

6000 P.S.I.G. Working Pressure Aluminum Body, Stainless Steel Piston, Ceramic Magnets, Buna N Seals, 2-1/2" Engineering Plastic Case with Shatter-Resistant Lens. 1/4" FNPT Back Connections. Accuracy $\pm 3-2-3\%$ Full Scale (Ascending).

PART NUMBERING SYSTEM

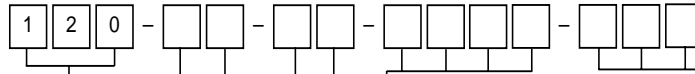

① BASIC MODEL NUMBER

② MATERIAL

- A. Aluminum Body, S.S. Piston (Standard)
- M. Monel Body (See 120 ABM) (5000 P.S.I.G. working pressure)
- N. Aluminum Bronze Body (See 120 ABM) (5000 P.S.I.G. working pressure)
- S. 316 S.S. Body & S.S. Piston (Standard)
- Z. SPECIAL (Uncoded Options)

③ DIAL TYPE

- A. 2-1/2" Round Uni-Directional Engrd. Plastic Housing Assy. (Standard)
- B. 2-1/2" Round Bi-Directional Engrd. Plastic Housing Assy.
- C. 4-1/2" Round Uni-Directional Engrd. Plastic Housing Assy.
- D. 4-1/2" Round Bi-Directional Engrd. Plastic Housing Assy.
- E. 3-1/2" Round Uni-Directional Anod. Aluminum Housing Assy.
- F. 3-1/2" Round Bi-Directional Anod. Aluminum Housing Assy.
- G. 4-1/2" Round Uni-Directional Anod. Aluminum Housing Assy.
- H. 4-1/2" Round Bi-Directional Anod. Aluminum Housing Assy.
- T. Non-Indicating Differential Pressure Switch Only (Select Appropriate Electrical Option)
- Z. Special (Uncoded Options)

④ SEALS

- 0. Buna N (Standard)
- 1. Viton®
- 2. Neoprene
- 4. Teflon®
- 5. Ethylene Propylene
- 6. Perfluoroelastomer
- 9. Special (Uncoded Options)

*Viton® is a Registered Trademark of DuPont Dow Elastomers.
**Teflon® is a Registered Trademark of DuPont.

⑤ CONNECTIONS

- (NOTE: Models 120M and 120N available only with end connections)
- 0. 1/4" FNPT Back Connections (Standard)
 - 2. 1/4" FNPT End Connections
 - 6. 7/16" - 20 Str. Thd. O-Ring Port (Back Connections)
 - 7. 1/2" FNPT Stainless Steel Adaptors
 - 8. 1/2" FNPT Monel Adaptors
 - 9. Special (Uncoded Options)

⑥ OPTIONS (Up to four options)

- O. None (Standard)
- A. Reversed High/Low Process Connections
- B. DIN2353 12-S (12mm) Steel Tube Fittings (2)
- C. Mounting Holes in Gauge Body for Field Mounting of Electrical Configurations Options A & B
- D. Mounting Holes in Gauge Body for Field Mounting of Electrical Configurations Options L & M
- F. Pipe Mounting Kit (Carbon Steel) (Not available w/C or D Electrical Switch Options)
- L. Liquid Fill (Not available w/follower pointer) (Not available with 3-1/2" dial)
- M. Maximum Indicator Follower Pointer
- T. Oxygen Cleaning
- U. S.S. Tag Mounted w/S.S. Wire
- V. S.S. Tag Mounted w/S.S. Screws
- W. Wall Mounting Kit
- X. Individual Gauge Packaging
- Z. Special (Uncoded Options)

⑦ ELECTRICAL CONFIGURATIONS

(NOTE: All options ^④ marked, except E, F, J & K)

- O. None
- A. One (1) Switch in STD. Enclosure with Grommet Wire Seal
- B. Two (2) Switches in STD. Enclosures with Grommet Wire Seal
- C. One (1) Switch in STD. Enclosure with 1/4" FNPT Electrical Connection NEMA 4X
- D. Two (2) Switches in STD. Enclosures with 1/4" FNPT Electrical Connection NEMA 4X
- E. One (1) Switch in General Purpose Enclosure, C.S.A. & U.L. Listed, Division II Locations ^{(1) (3)}
- F. Two (2) Switches in General Purpose Enclosure, C.S.A. & U.L. Listed, Division II Locations ^{(1) (3)}
- G. One (1) Switch & Gauge in NEMA 4X Plastic Enclosure (Not Available With End Connections)
- H. Two (2) Switches & Gauge in NEMA 4X Plastic Enclosure (Not Available With End Connections)
- J. One (1) Switch in Explosion Proof Enclosure with Glass Window Cover and C.S.A. & U.L. Listing ⁽²⁾
- K. Two (2) Switches in Explosion Proof Enclosure with Glass Window Cover and C.S.A. & U.L. Listing ⁽²⁾
- L. One (1) Switch in STD. Enclosure with Plug-In Connector (DIN 43650/IP65-PG11)
- M. Two (2) Switches in STD. Enclosure with Plug-In Connector (DIN 43650/IP65-PG11)
- Z. Special (Uncoded Options)

⁽¹⁾ Complete Assembly Rated Class I, Div. II, Groups A, B, C, & D; Class II, Div. II, Groups F and G.

⁽²⁾ Complete Assembly Rated Class I, Div. I, Groups C & D; Class II, Div. I, Groups E, F, & G.

⁽³⁾ 5000 PSIG Working Pressure.

⑧ ELECTRICAL SPECIFICATIONS (For Resistive Loads)

- A. S.P.D.T., 3W, 0.25 Amp., 125 VAC/VDC (Standard) (Switch adjustable range of 10-90%)
- E. S.P.S.T., 60W, 3.0 Amp., 240 VAC/VDC (Normally Open) (Switch adjustable range of 25-95%)
- F. S.P.S.T., 60W, 3.0 Amp., 240 VAC/VDC (Normally Closed) (Switch adjustable range of 25-95%)
- G. S.P.S.T., 60W, 3.0 Amp., 240 VAC/VDC One (1) Normally Open, One (1) Normally Closed ⁽⁴⁾
- H. S.P.D.T., 60W, 1.0 Amp., 240 VAC/VDC (Switch adjustable range of 25-100%)
- Z. Special (Uncoded Options)

⁽⁴⁾ Available with Electrical Configurations B, D, F, H, K and M only.

NOTE: NOT ALL OPTIONS AVAILABLE IN COMBINATION WITH OTHER OPTIONS.

NOTE: FACTORY PRESET SWITCHES AT NO CHARGE (SPECIFY SETTING)

NOTE: THE USE OF DIAPHRAGM SEALS IS NOT RECOMMENDED FOR MODEL 120 SERIES GAUGE. ATTEMPTS TO INSTALL SUCH SEALS ON THIS GAUGE WILL VOID THE WARRANTY.

⑥ - (Up to three options)

MOUNTING INFORMATION & DIMENSIONAL DATA

MODEL 120: 2-1/2" INCH PLASTIC DIAL ASSY.

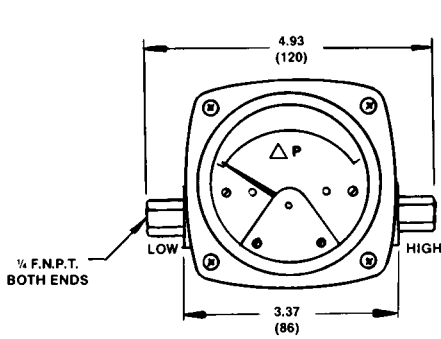

END CONNECTION (OPTIONAL)

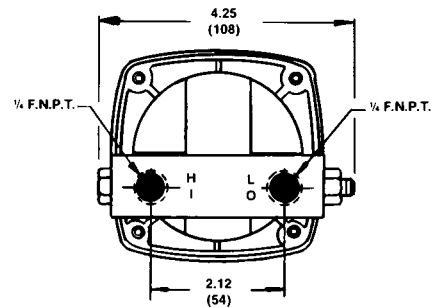
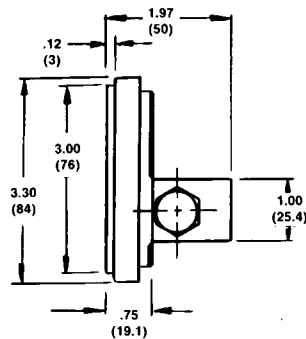

BACK CONNECTION (STANDARD)

MODEL 120: 4-1/2" INCH PLASTIC DIAL ASSY.

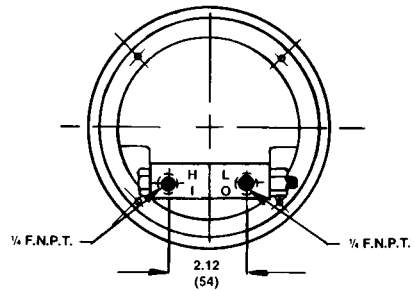
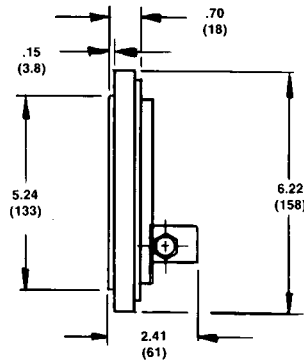
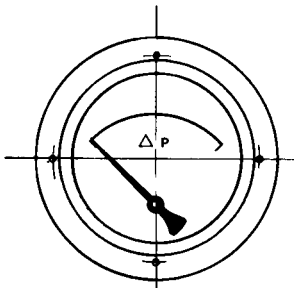

- NOTES: 1. Drawings show standard gauge nominal dimensions. (not to scale)
 2. Dimensions shown in parentheses are in millimeters.
 3. Mounting dimensions for 3-1/2" & 4-1/2" alum. Dial assys. – Contact Factory

Manufacturer reserves the right to change specifications without prior notice.

PROOF PRESSURE: 12,000 PSI for models 120-A and 120-S.
 10,000 PSI for models 120-M and 120-N.

TEMPERATURE LIMITS: -40°F(-40°C) to +200°F(+93°C) - These limits are based on the entire instrument being saturated to these temperatures. System (process) temperatures may exceed these limitations with proper installation. Contact our customer service representative for details.

STANDARDS: All Model 120 Series differential pressure gauges either conform to and/or are designed to the requirements of the following standards:

ASME B1.20.1
 ASME B40.1
 CSA-C22.2 No. 14.25 and 30
 EN-61010-1

NACE MR0175
 NEMA Std. No. 250
 SAE J514
 UL Std. No. 50,508 and 1203



REPRESENTED BY:

Mid-West[®]
 Instrument

6500 Dobry Dr. □ Sterling Heights, MI 48314 U.S.A.
 (586) 254-6500 □ FAX (586) 254-6509
 E-mail: sales@midwestinstrument.com
 Website: www.midwestinstrument.com

Printed in U.S.A.