

Bourdon Tube Pressure Gauge Type 111.16 Panel Mount Gauge For Metric Size Panel Cutouts Standard Series

WIKA Datasheet 111.16

Applications

- Pneumatics
- HVAC
- Suitable for all media that will not obstruct the pressure system or attack copper alloy parts

Special features

- Reliable and economical
- Ranges up to 6,000 psi
- Fits metric size panel holes

Standard Features

Design

EN 837-1 & ASME B40.100

Sizes

1½" & 2" (40 & 50 mm)

Accuracy class

± 3/2/3% of span (ASME B40.100 Grade B)

Ranges

Vacuum / Compound to 200 psi
Pressure from 15 psi to 6,000 psi
or other equivalent units of pressure or vacuum

Working pressure

Steady: 3/4 of full scale value
Fluctuating: 2/3 of full scale value
Short time: full scale value

Operating temperature

Ambient: -40°F to 140°F (-40°C to 60°C)
Media: 140°F (+60°C) maximum

Temperature error

Additional error when temperature changes from reference temperature of 68°F (20°C) ±0.4% for every 18°F (10°C) rising or falling. Percentage of span.

Connection

Material: Copper alloy
1/8" or 1/4" NPT center back mount (CBM)



Bourdon Tube Pressure Gauge Type 111.16

Bourdon Tube

Material: Copper alloy
15 psi to 600 psi: C-type
800 psi to 6,000 psi: helical

Movement

Copper alloy

Dial

White ABS with stop pin and black lettering

Pointer

Black ABS

Case

Black ABS with integral profile ring

Window

Snap-in acrylic

U-clamp bracket

Zinc-plated steel with two zinc-plated slotted screws

Optional Extras

- $\pm 2/1/2\%$ accuracy (ASME B40.100 Grade A)
- Front flange
- Crimped stainless steel profile ring
- Cleaned for oxygen service
- Special threaded connection
- Custom dial layout
- Other pressure scales available: Bar, kPa, MPa, kg/cm² and dual scales

Dimensions

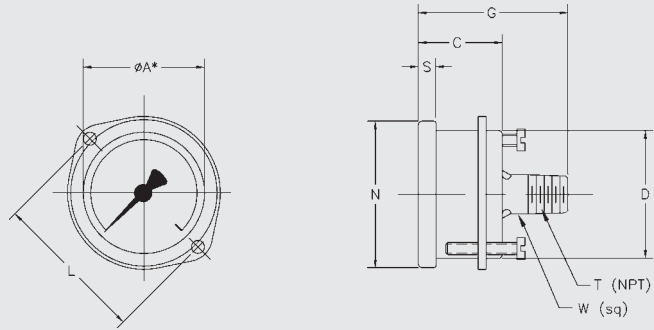

| Size | | A | C | D | G | N | S | T | W | Weight |
|-------------|----|-----|------|------|------|------|------|------|------|---------|
| 1.5" | mm | 40 | 26.5 | 40 | 45 | 45 | 4.5 | | 14 | |
| | in | 1.5 | 1.04 | 1.57 | 1.77 | 1.77 | 0.18 | 1/8" | 0.55 | 0.14 lb |
| 2" | mm | 50 | 26.5 | 49.5 | 47 | 54 | 4.5 | | 14 | |
| | in | 2.0 | 1.04 | 1.95 | 1.85 | 2.13 | 0.18 | 1/4" | 0.55 | 0.16 lb |

Ordering information

Pressure gauge model / Nominal size / Scale range / Size of connection / Optional extras required
 Specifications and dimensions given in this leaflet represent the state of engineering at the time of printing.
 Modifications may take place and materials specified may be replaced by others without prior notice.



WIKAL Instrument Corporation
 1000 Wiegand Boulevard
 Lawrenceville, GA 30045
 Tel (770) 513-8200 Toll-free 1-888-WIKA-USA
 Fax (770) 338-5118
 E-Mail info@wika.com
 www.wika.com